



A.D.R. S.p.A.
Via Antonio Maria Ceriani, 96 - 21040 Uboldo (VA) (ITALIA)
Tel. +39 02 96 17 11 - Fax +39 02 96 17 14 20 - adr@adraxles.com

www.adraxles.com

ADR
group

ALPHA HYDRAULISCHE AUFHÄNGUNGEN
ALPHA
HYDRAULIC SUSPENSIONS RANGE

ALPHA
SUSPENSION 15



ALPHA
SUSPENSION 18



moving innovation

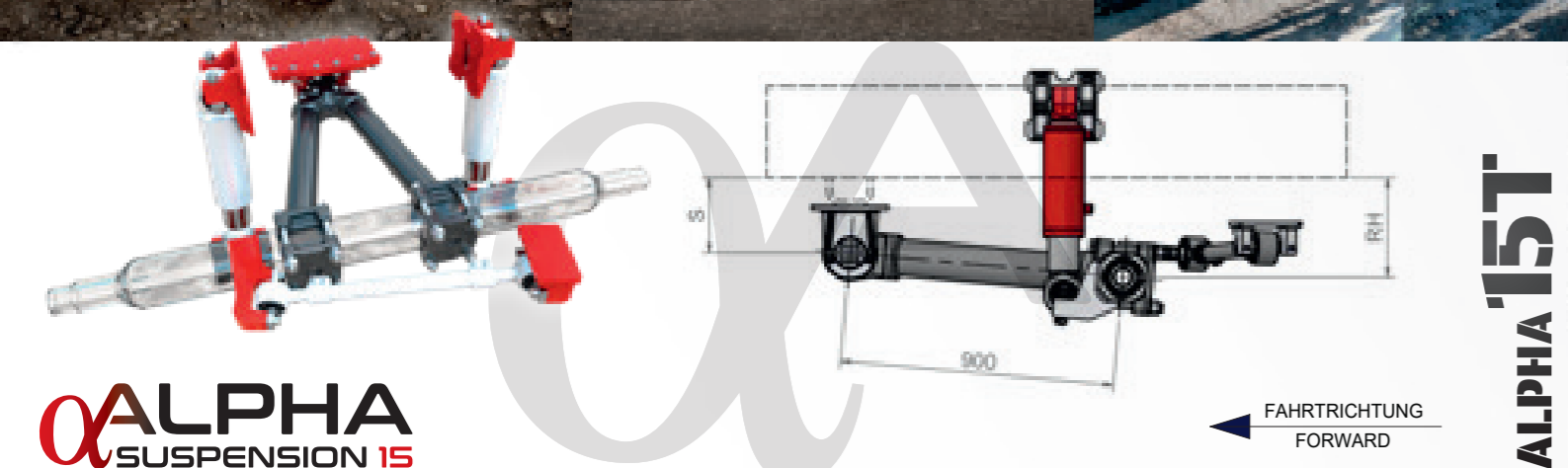

ALPHA 15T

Code Code	Achse Axle	Traglast Load kg	Zylinder Cylinder Ø mm	RH (Min. / Max.) mm	S mm
WA15... XA15...	150	15 000	Ø120-Ø100	327 (190-444)	248

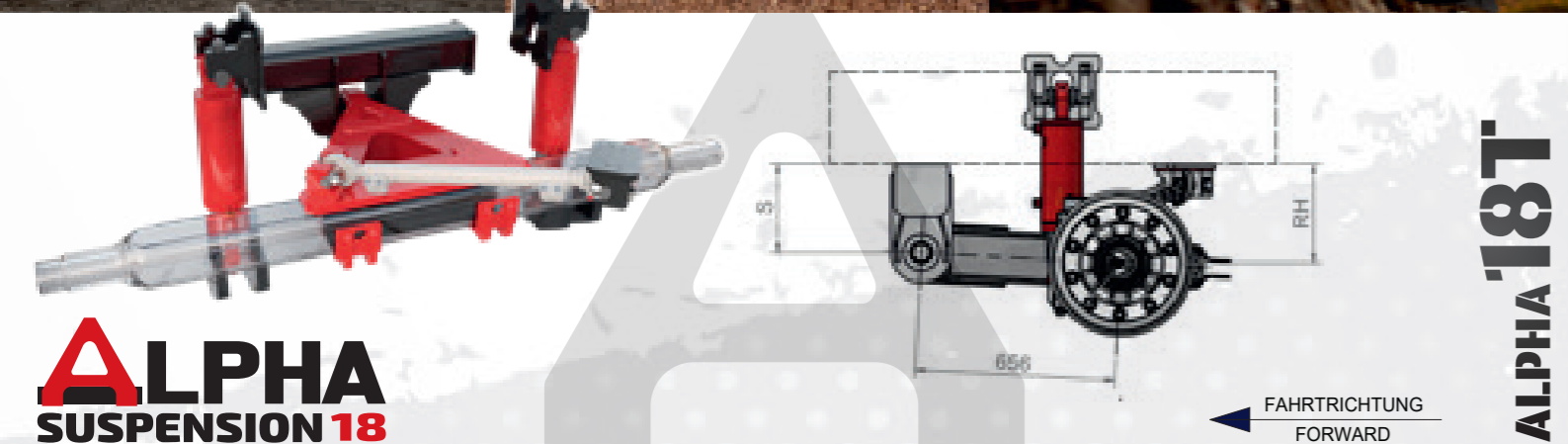

ALPHA 18T

Code Code	Achse Axle	Traglast Load kg	Zylinder Cylinder Ø mm	RH (Min. / Max.) mm	S mm
WA18...	150	18 000	Ø120-Ø100	328 (216-490)	293



COLAERT ESSIEUX sas
11 bis Route Nationale
59189 Steenbecque FRANCE
Tel. +33 3 28 43 85 50 - Fax +33 3 28 43 68 63
commercial@colaertessieux.fr - www.colaertessieux.fr



OMEGA Drives Inc.
7A-845 Lagimodiere Blvd. Winnipeg,
Manitoba R2J 3M2 CANADA
Tel. +1 204 453 24 77 - Fax +1 204 453 24 78
info@omegadives.com - www.omegadives.com



ADR Polska sp. z o.o.
ul. Bieszczadzka 5, 38-540 Zagórz, POLSKA
Tel. +48 13 46 89 333 - Fax +48 13 46 89 368
atw@atwsystem.pl - www.adrosie.pl

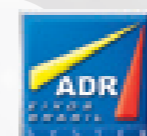

ADR EIXOS BRASIL Ltda
Rua Nelson Colela, 105 Ribeirão Preto SP,
CEP 14072-068 BRASIL
Tel. +55 16 3617.3079
info@adreixos.com.br - www.adraxles.com.br



ADR UK - Tyremart Agricultural Ltd
Main Road, Long Bennington, Newark,
Notts, NG235DJ - UNITED KINGDOM
Tel. +44 1400 28 38 20 - Fax +44 1400 28 31 37
info@tyremartagri.co.uk - www.adraxles.com



ADR China - Qingdao ADR Axles Manufacturing Co., Ltd.
Lingang Road No.2468, Huangdao District, Qingdao,
Shandong Province - 266400 CHINA
Tel. +86 532 86 19 66 36 - Fax +86 532 86 19 65 01
info@adrsystem.cn - www.adraxles.cn



ADR GEPLASMETAL sau
Pol. Malpica c/ J n°1 - 50.016 Zaragoza ESPAÑA
Tel. +34 976 46 52 54 - Fax. +34 976 57 11 32
info@adrgeplasmetal.com - www.adrgeplasmetal.com



ADR Axles India Pvt. Ltd.
Plot No I-10, Khed City Industrial Park DTA
Kanhersar Village, Rajgurunagar, Pune
410505, Maharashtra INDIA
Tel. +91 8806 078698 - info@adraxles.in - www.adraxles.in



ADR Axles USA Inc.
1100 South Tower 225 Peachtree St. NE - Atlanta
Georgia - 30303 - USA | Tel. +1 336 480-4234
adr@adraxlesusa.us - www.adraxles.com



ADR Australia Pty Ltd
Unit 1/11 Warrior Place,
St. Marys NSW 2760 - AUSTRALIA
Tel. +61 2 96 23 05 12 - Fax +61 2 96 23 05 05
admin@adraust.com.au - www.adraust.com.au





ALPHA SUSPENSION 15

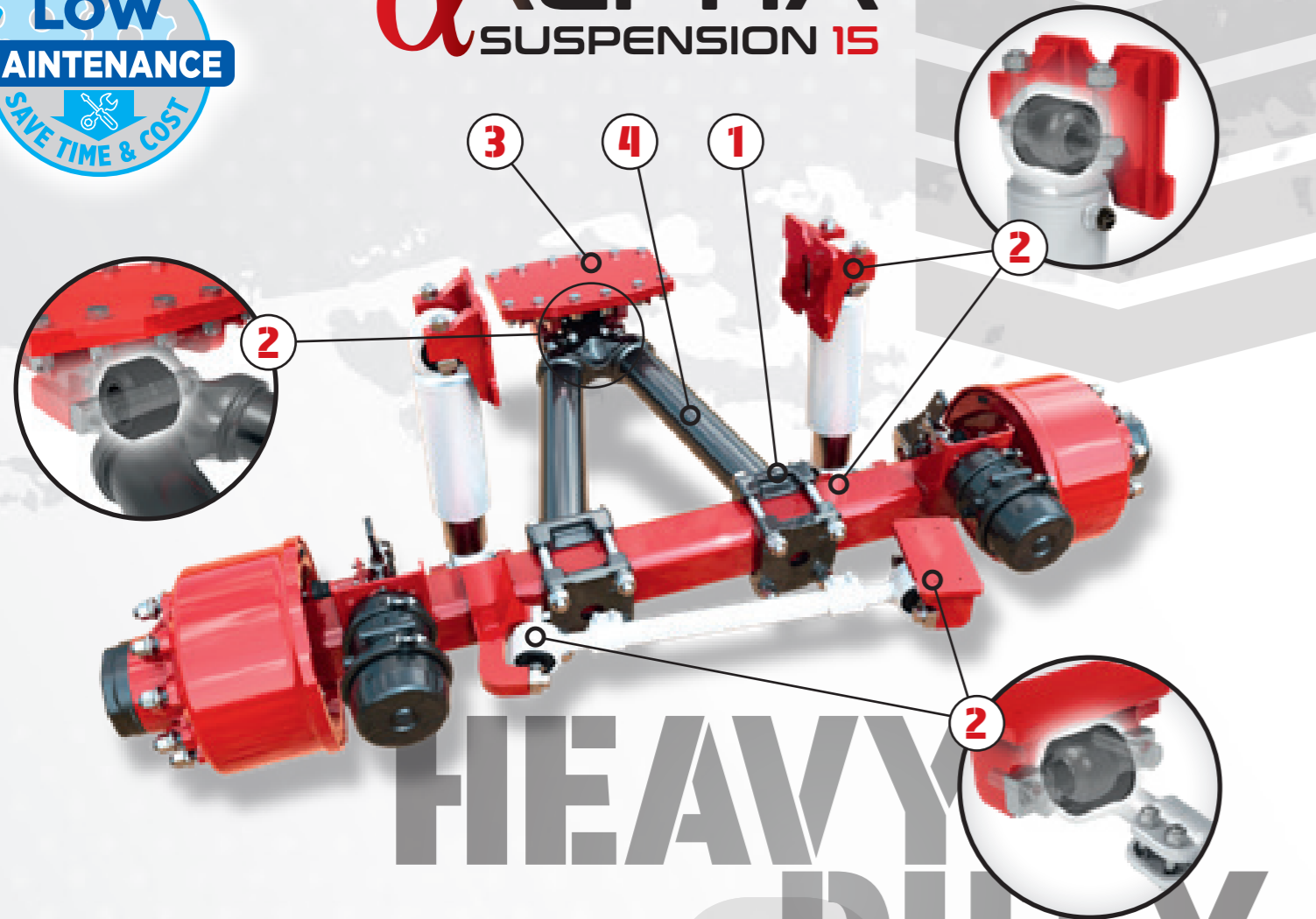

VORTEILE ALPHA '15T'

- 1 Nahtloses Klemmen:** Gewährleistet Vielseitigkeit bei der Wahl des Achstyps. Eliminiert Schweißnähte an der Achse. Es ermöglicht Lieferung in Kits.
Seamless Clamping: Ensures versatility in the choice of axle type. Eliminate welds in body axle. It ensures the possibility of supply in kits.
- 2 Elastische Kugelgelenke:** durch spezielle Buchsen werden Schmiervorgänge vermieden. "Wartungsarm"
Elastic spherical ball joints: by means of special bushings lubrication that avoided operations. "Low Maintenance"
- 3 Verschraubte Konsole:** Die Befestigung am Rahmen ist einfach, vielseitig und an jeden Anhängertyp anpassbar.
Bolted console: fixing to the frame is simple, versatile and customizable on any type of trailer.
- 4 Optimiertes Dreiecksgelenk:** hergestellt aus Rohren mit integrierten Stahlguss-elementen, wodurch Leichtigkeit, geringe Gesamt-abmessungen und die notwendige Steifigkeit gewährleistet werden.
Slender triangular joint: made with tubes integrated with cast steel elements thus ensuring lightness, low overall dimensions and essential rigidity.

ALPHA '15T'



VORTEILE DER ALPHA REIHE ADVANTAGES OF THE RANGE

- Befestigung der Zylinder und des Stabilisators auf **Bolzen**, um die **Montage und Demontage zu vereinfachen**.
- Fixing cylinders and stabilizer bar on **bolted pins to facilitate and simplify** any assembly and disassembly operations.
- Stabilisatorkonstruktion mit **integrierten geschmiedeten Enden, stark und haltbar**. Die Konstruktion der Stange ermöglicht eine einfache Einstellung der Aufhängungsausrichtung an jeder Stelle und nur durch Drehen des Mittelrohrs.
- Stabilizer bar construction with **integral forged terminals, strong and durable**. The bar design allows for easy adjustment of the suspension alignment anywhere and only by rotating the center tube.
- Fahrgestellseitige **Zylinderbefestigungen werden fertig zur Anpassung an den Anhängerrahmen geliefert**.
- Chassis side **cylinder attachments are supplied ready** to be adapted to the trailer frame.
- Hoher vertikaler Hub** der Achse, ca. 250 mm (+/-125).
- High vertical stroke** of the axle, about 250mm (+/- 125).
- Hoher Roll/ Querneigungswinkel**, bis zu ca. 12 Grad, ohne jeglichen Widerstand, um die die Fahrstabilität des Anhängers auch auf schwierigstem Gelände zu gewährleisten.
- High rolling inclination angle**, up to about 12 degrees, without any resistance to guarantee the trailer's running stability even on more difficult terrain.
- Die achsseitigen Zylinderbefestigungen können entsprechend den auszurüstenden Anhängern **frei positioniert werden**, da sie von der Dreiecksverbindung entkoppelt sind.
- Axle-side cylinder attachments can be positioned freely** according to the trailers to be equipped, being decoupled from the triangular joint.

ALPHA '15T'

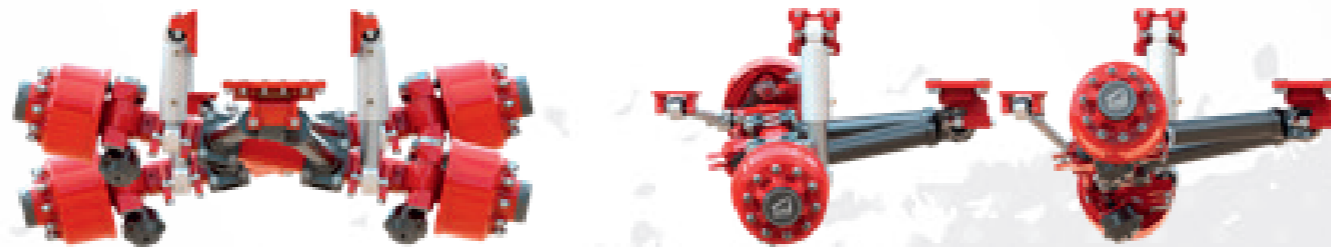

ALPHA '18T'



ALPHA SUSPENSION 18

VORTEILE ALPHA '18

- 1 Kugelgelenke aus Spezialstahl:** kompakt und extrem belastbar.
Spherical ball joints in special steel: compact and allow extreme loads.
- 2 Dreieckiges, mit der Achse integriertes Gelenk:** Die Konstruktion gewährleistet eine extreme Ausrichtung und hohe Steifigkeit.
Triangular joint integral with the axle: the construction guarantees extreme alignment and high stiffness.
- 3 Dreiecksgelenk aus verstärktem, geschweißtem Blech:** garantiert eine hohe mechanische Festigkeit und minimiert Verformungen bei maximaler Tragfähigkeit.
Triangular articulation in reinforced welded sheet metal: guarantees high mechanical resistance and minimizes deformations to maximum load capacities.

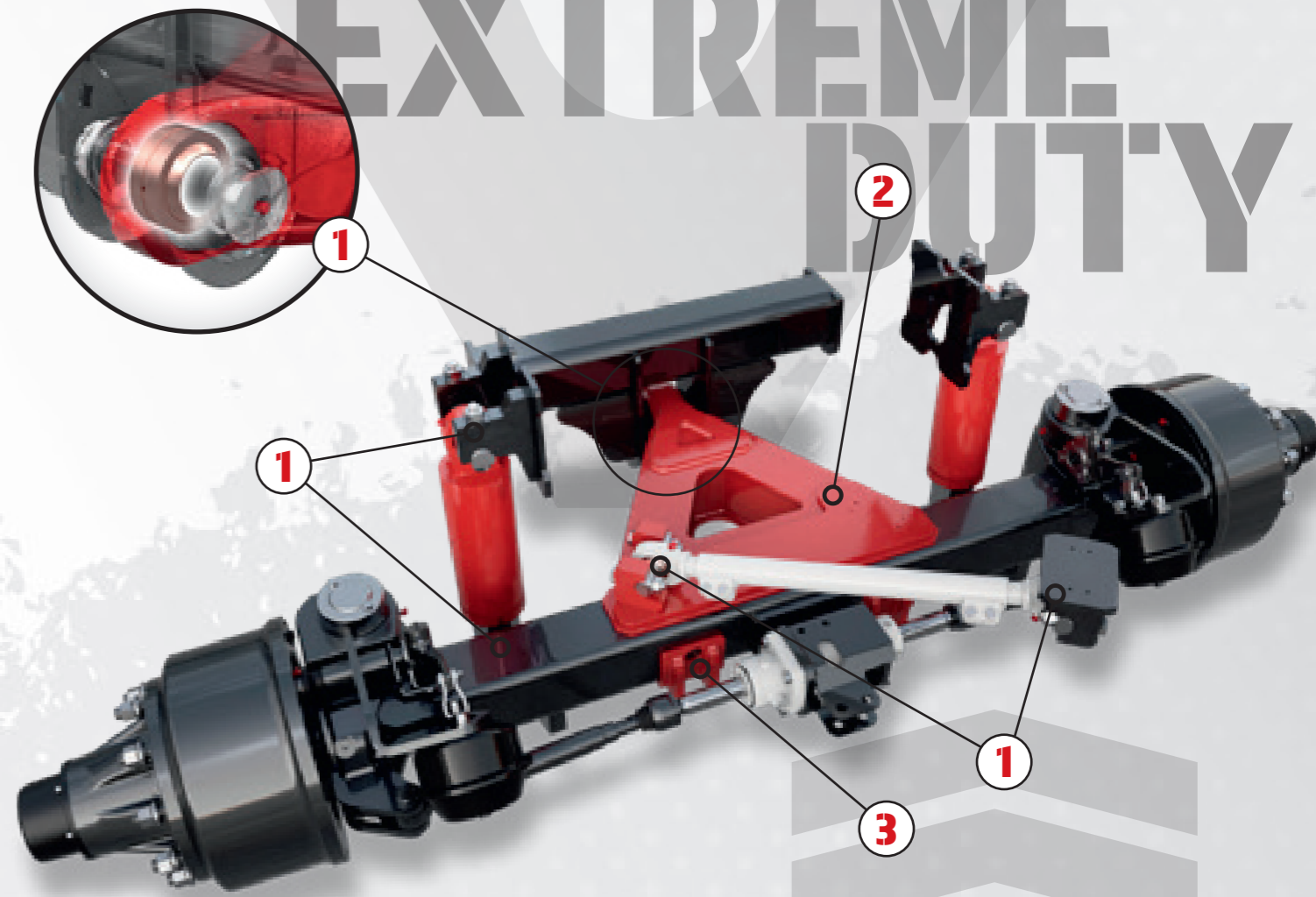

ALPHA '18T'